

ENVAIR

Integrity in clean air

Products Range

- High Containment Isolators
- Negative Pressure Isolators
- Positive Pressure Isolators
- Horizontal Laminar Flow Cabinets
- Downflow Booths
- Microbiological Safety Cabinets
- Open and Closed RABS
- Fume Cupboards

Healthcare



Biotech



Pharmaceuticals



+353 (0)61 326921



info@essltd.ie



Follow us
on LinkedIn

For further information, or to speak to one of our dedicated sales team, contact us:

IN IRELAND CONTACT
Eirdata Ltd.
Ireland: 4 Shelbourne Road,
Limerick, Ireland.

Eirdata

Phone: +353 (0)61 326921
Fax: +353 (0)61 326112
Email: info@eirdata.ie

www.envair.co.uk

ENVAIR

Integrity in clean air

Healthcare | Biotech | Pharmaceuticals Industry



Providing you
with standard
and customisable
solutions

Ideal for:

- Sterility Testing
- Aseptic Processing
- Sterile Powder Handling
- Sterile Transfer

STERICARE ISOLATOR

For all Enclosed Sterility Applications

Call our dedicated sales team tel +353 (0)61 326921

COMPLIANT AND USER-FRIENDLY DESIGN

Key Design Features

- EU GMP Grade A Unidirectional Airflow
- ISO 14644 Class 5 air quality in all chambers
- Two or Four Glove Main Chamber available as standard
- Configurable for positive or negative pressure regimes
- H14 HEPA filtration throughout in accordance with BS EN 1822
- Room recirculating or fully ducted configurations available
- HMI Touchscreen control interface
- Modular construction
- VHP System integration
- Enhanced Integration of Sterility Test Pump
- Automated pressure decay functionality
- Viable air sampling control via isolator HMI
- Integrated non-viable air sampling
- Full System and Hatch only decontamination functionality
- Rigid isolator construction
- All product contact surfaces polished 316L stainless steel
- Printable gas cycle reports

Optional Extra's

- RTP transfer port
- External fully polished stainless steel construction
- GAMP 5 compliance package
- Customisable product racking
- Onboard H2O2 monitor
- Internal power sockets

HATCH DECONTAMINATION IS AS LITTLE AS 30 MINUTES FULLY LOADED

High frequency and repeatable gas cycle times for quick throughput application

SAFE HANDS WITH ENVAIR

UDAF Grade A environment



Siemens screen

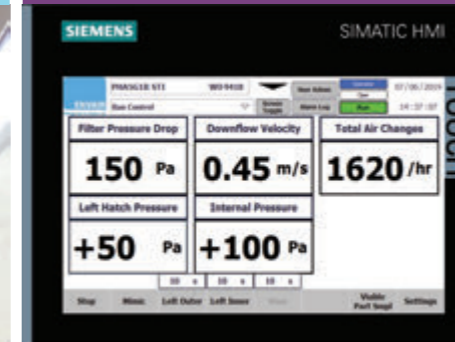

Excellent aeration times



STERICARE: The Modular Approach

Whether choosing a standard or custom solution, STERICARE's modular approach means we can work with you to come up with a configuration that best suits your process workflow

STERICARE Compact

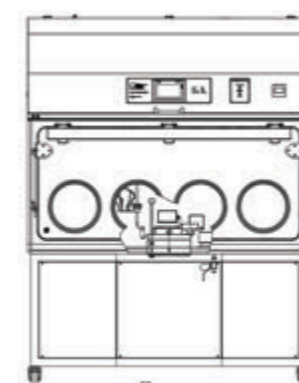

STERICARE Single (LH or RH)

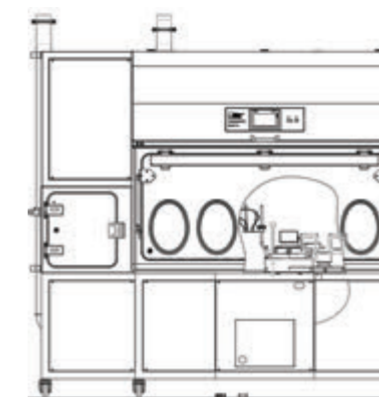

STERICARE Multi +

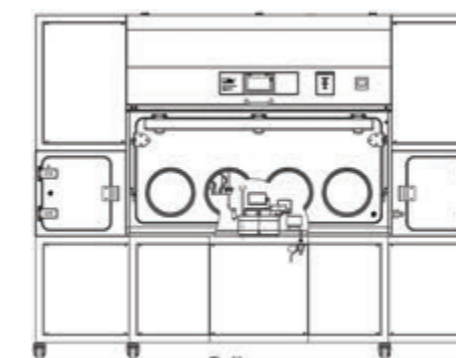

STERICARE Isolator Dimensions

STERICARE Compact	Width 1800mm / 70"	Height 2350mm / 92 ½"	Depth 1255mm / 49 ¾"
STERICARE Single	Width 2420mm / 95 ¼"	Height 2350mm / 92 ½"	Depth 1255mm / 49 ¾"
STERICARE Multi +	Width 3075mm / 121"	Height 2350mm / 92 ½"	Depth 1255mm / 49 ¾"
Main Chamber 'Four Glove'	Width 1800mm / 70 ¾"	Height 2850mm / 112"	Depth 725mm / 28 ½"
Main Chamber 'Two Glove'	Width 1200mm / 47 ¼"	Height 2850mm / 112"	Depth 725mm / 28 ½"
Hatch	Width 600mm / 23 ⅝"	Height 580mm / 22 ¾"	Depth 490mm / 19 ¼"

STERICARE – Customer Care

Envair recognise that customer satisfaction extends far beyond the delivery and validation of your chosen sterility isolator. Thus, Envair provide multi-year, multi-level service and maintenance contracts to give you peace of mind that your STERICARE Isolator continues to operate at peak performance for years to come.

To support this, Envair also stock a large variety of parts to allow quick customer response times.

The Envair Approach

- Modular Design to suit your process
- High process throughput capability
- Transfer hatch 6 log spore reduction in **30 mins**
- VHP System integration
- Standard and customisable solutions